

0.13μm Synchronous High Speed Dual-Port Static Memory Compiler – FSC0H_D_SJ

Key Features

- Operating voltage range: 1.08V ~ 1.32V
- Operating junction temp. range: -40°C ~ 125°C
- Recommended operating ambient temp. range: 0°C ~ 85°C
- Minimum metal requirement: 5 metal layers
- Synchronous read and write operations
- Fully customized layout density
- Automatic power down mechanism to eliminate DC current
- Clocked address inputs and CSA(B) to RAM with CKA(B) rising edge
- Clocked WEA(B)N input pins to RAM with CKA(B) rising edge
- Clocked DIA(B) input pins to RAM with CKA(B) rising edge
- Byte write or word write operations available
- Memory compiler preview UI (Memaker)
- BIST circuit supported
- Multi-block options for the best aspect ratio

General Description

The FSC0H_D_SJ is a synchronous, high speed, dual-port SRAM. It is created according to UMC's 0.13μm high speed technology. Different combination of words, bits, and aspect ratios can be used to generate the most desirable configurations.

By requesting the desired size and timing constraints, the FSC0H_D_SJ compiler is capable of providing suitable synchronous SRAM layout instances in minutes. It also automatically generates data sheets, Verilog / VHDL behavioral simulation models, SCS or Viewlogic symbols, place & route models, and test patterns for use in ASIC designs. The length of duty cycle can be neglected as long as the setup / hold time and minimum widths of high / low pulse are satisfied. This allows the flexibility of a clock falling edge during each operation. Both word write and byte write operations are supported.

Symbol

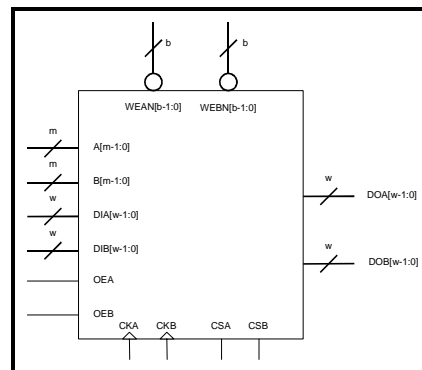

Quick Reference

Maximum Capacity	512K bits
Maximum Words	32K
Minimum Words	64
Maximum Bits	128
Minimum Bits	1
Bit Increment	1
Aspect Ratio (Block Mux)	1, 2, 4, 8

HEADQUARTERS

Hsinchu, Taiwan.
 Tel: 886-3-578-7888
 Fax: 886-3-578-7889
 sales@faraday.com.tw

USA OFFICE

Sunnyvale, USA
 Tel: 1-408-522-8888
 Fax: 1-408-522-8889
 sales@faraday-usa.com

EUROPE OFFICE

Hoofddorp, Netherlands
 Tel: 31-2356-20496
 Fax: 31-2356-36297
 eusales@faraday.com.tw

JAPAN OFFICE

Tokyo, Japan
 Tel: 81-3-5214-0070
 Fax: 81-3-5214-0076
 sales@faraday.co.jp

CHINA OFFICE

Shanghai, P. R. China
 Tel: 86-21-6406-7523
 Fax: 86-21-6406-5327
 sales@faraday.com.cn